

BUILDING DESCRIPTION	
VALUATION METHOD:	R - RESIDENTIAL
USE CODE:	D - DWELLING
STYLE:	C - CONVENTIONAL
FOUNDATION:	C - CONTINUOUS WALL
EXTERIOR WALL 1:	F - FRAME
EXTERIOR WALL 2:	ST - STONE
ROOF STRUCTURE:	H - HIP
ROOF COVER:	A - ASPH SHINGLE
BEDROOMS:	3
FULL BATHS:	3
HALF BATHS:	1
ADDITIONAL FIXTURES:	
FIREPLACE TYPE/CNT/OPN/CH:	
ELEVATOR TYPE/COUNT/STOPS:	
PHYS OVERRIDE:	
ECONOMIC DEPRECIATION:	
FUNCTIONAL DEPRECIATION:	
SPECIAL CONDITION CODE:	
SPECIAL CONDITION VALUE:	
DESCRIPTION:	1.5/S FR DWLG & B
REMARKS:	
HEATED SQUARE FEET:	2,378

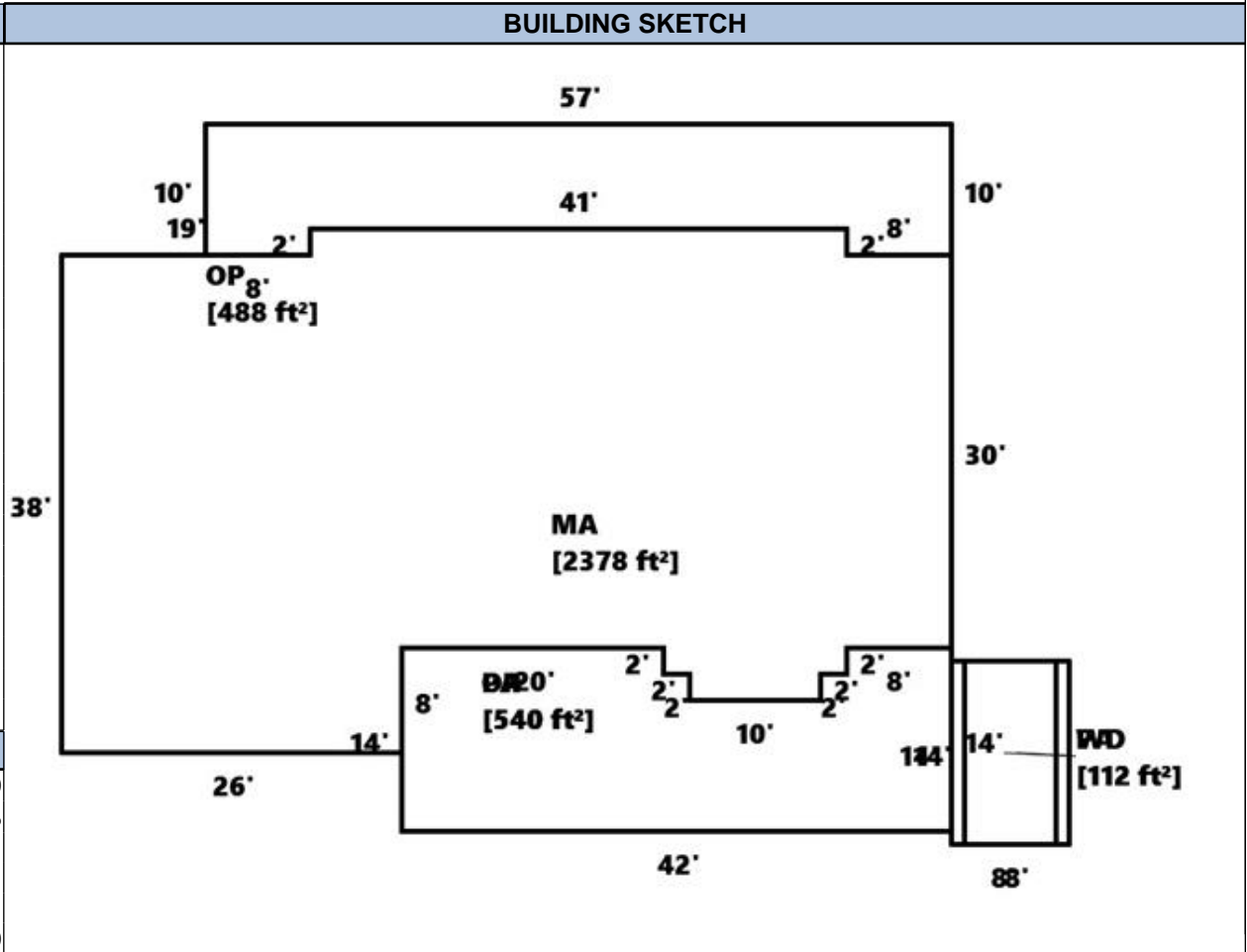

BUILDING COMPUTATION	
REPLACEMENT COST NEW	792,720
PHYSICAL DEPRECIATION	18%
FUNCTIONAL DEPRECIATION	
ECONOMIC DEPRECIATION	
% COMPLETE	
REPLACEMENT COST NEW LESS DEPRECIATION	650,120

BUILDING SECTION DETAIL														
TYPE	AREA	#ST	HEAT TYPE	HEAT%	AIR%	SPRINKLER%	GRADE	AYB	EYB	COND	P%	E%	F%	VALUE
MA	2378	1.5	F		100%		B	2003	2003	A	82%			374720
LLF	1784	1.0									82%			143600
LLU	594	1.0									82%			13500
OP	540	1.0									82%			23000
OP	488	1.0									82%			20800
PA	112	1.0									82%			800
PA	540	1.0									82%			3800
UUS	1189	1.0									82%			67500
WD	112	1.0									82%			2400