

KRAMER, RICHARD M.  
 KRAMER, BARBARA W.  
 808 SUNSET MOUNTAIN  
 CHATTANOOGA, TN 37421  
 ACCOUNT NUMBER: 132990

# Macon County, North Carolina

Parcel: 6567743362  
 Tax Year: 2026  
 Reval Year: 2023  
 Appraised By: 25 on 10/06/2022  
 Information Source: E - ESTIMATE

**Tax Districts**  
 GENERAL COUNTY TAX, LANDFILL FEE RESIDENTIAL (1), BURNINGTOWN FIRE  
 DISTRICT TAX

PARCEL INFORMATION		PROPERTY DESCRIPTION				SALES INFORMATION			
<b>Address:</b>	197 MOUNTAIN WHISPERS DR	TRACT 4 MOUNTAIN WHISPERS 3.1900 AC				<b>Date</b>	<b>Sales Price</b>	<b>Valid</b>	<b>Book / Page</b>
<b>Neighborhood:</b>	10002 - LOWER BURNINGTOWN					5/20/2014	35000	Y	F-36/761
		PERMIT INFORMATION							
<b>Road Type:</b>	T - PRIVATE DIRT	Code	Date	Permit #	Amount				
<b>Township:</b>	10 - BURNINGTOWN								
<b>Utilities:</b>	S-1, W-1								
<b>View:</b>						<b>Plat Book:</b>		<b>Plat Card:</b>	

NOTES	VALUE SUMMARY
listed for 1499000 6/25, reduced to 1,339,000 10/25	<b>LAND:</b> 89,180 <b>BUILDING:</b> 839,180 <b>OBXF:</b> 60,900 <b>TOTAL APPRAISED:</b> 989,260 <b>DEFERRED VALUE:</b> 0 <b>NET TAXABLE:</b> 989,260

LAND DATA - MARKET VALUE														
MTH	CODE	DESCRIPTION	ZONING	TOPO 1	TOPO 2	PRICE PER ACRE	ACRES	ADJ 1	ADJ 2	ADJ 3	UTILITIES	VALUE	NOTES	
1	A	0150	RES VIEW		R	27,956	3.190				10,000	89,180		
<b>Total Acres:</b>							<b>3.190</b>	<b>Total Land Value:</b>					<b>89,180</b>	

OUTBUILDING DATA																	
CODE	DESC	GRADE	COUNT	LENGTH	WIDTH	UNITS	UNIT PRICE	STORIES	AYB	EYB	COND	PHYS	FOBS	EOBS	% CMPLT	TAX VALUE	NOTES
56	SHOP, FRAME	B				672			2015	2015	A					48200	SHOP
61	STORAGE, FR UTILITY	B				320			2017	2017	A					12700	

**BUILDING DESCRIPTION**

VALUATION METHOD: R - RESIDENTIAL  
 USE CODE: D - DWELLING  
 STYLE: C - CONVENTIONAL  
 FOUNDATION: C - CONTINUOUS WALL  
 EXTERIOR WALL 1: F - FRAME  
 EXTERIOR WALL 2: ST - STONE  
 ROOF STRUCTURE: G - GABLE  
 ROOF COVER: A - ASPH SHINGLE  
 BEDROOMS: 3  
 FULL BATHS: 3  
 HALF BATHS: 2  
 ADDITIONAL FIXTURES:  
 FIREPLACE TYPE/CNT/OPN/CH: FP/1/2/2  
 ELEVATOR TYPE/COUNT/STOPS:  
 PHYS OVERRIDE:  
 ECONOMIC DEPRECIATION:  
 FUNCTIONAL DEPRECIATION:  
 SPECIAL CONDITION CODE:  
 SPECIAL CONDITION VALUE:  
 DESCRIPTION: 1.5/S FR DWLG & B  
 REMARKS:  
 HEATED SQUARE FEET: 2,561

**BUILDING SKETCH**

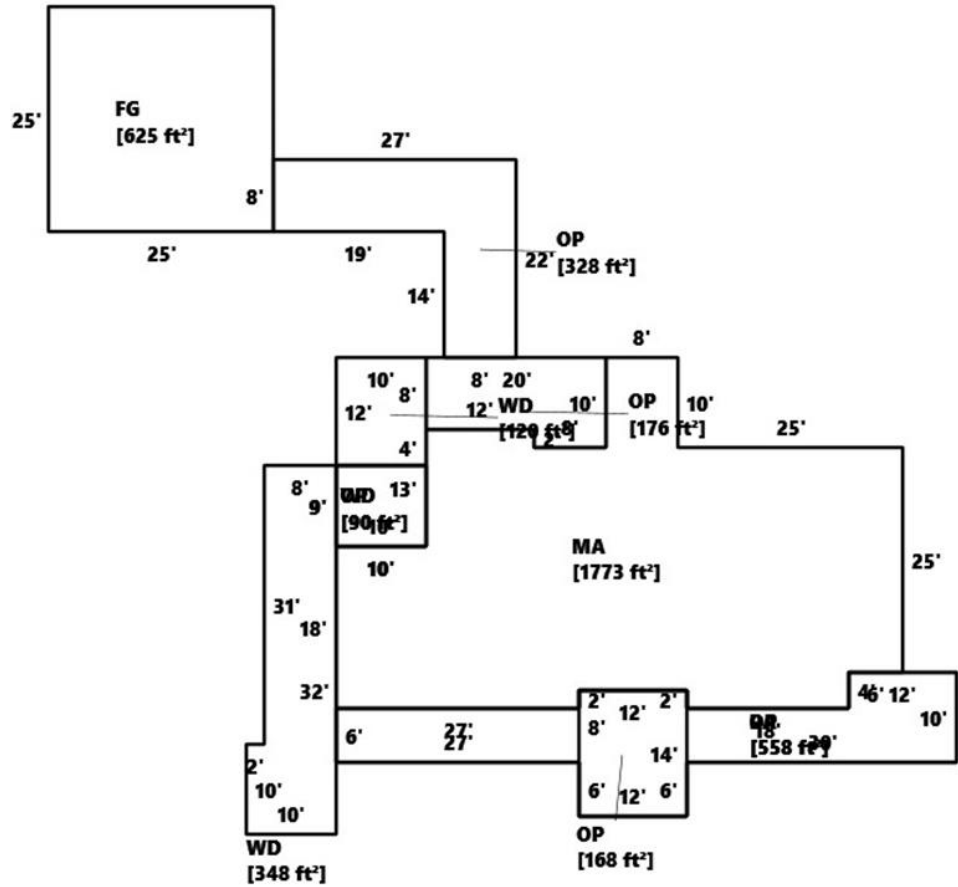

**BUILDING COMPUTATION**

REPLACEMENT COST NEW	902,620
PHYSICAL DEPRECIATION	7%
FUNCTIONAL DEPRECIATION	
ECONOMIC DEPRECIATION	
% COMPLETE	
REPLACEMENT COST NEW LESS DEPRECIATION	839,180

**BUILDING SECTION DETAIL**

TYPE	AREA	#ST	HEAT TYPE	HEAT%	AIR%	SPRINKLER%	GRADE	AYB	EYB	COND	P%	E%	F%	VALUE
MA	1773	1.5	P		100%		B+10	2014	2014	A	93%			377880
FG	625	1.0									93%			69100
FUS	788	1.0									93%			133600
LLF	1507	1.0									93%			157400
LLU	266	1.0									93%			7800
OP	176	1.0									93%			9700
OP	168	1.0									93%			9300
OP	328	1.0									93%			18100
OP	90	1.0									93%			5000
OP	558	1.0									93%			30800
PA	558	1.0									93%			5100
WD	120	1.0									93%			3300
WD	348	1.0									93%			9600

