

BUILDING DESCRIPTION	
VALUATION METHOD:	R - RESIDENTIAL
USE CODE:	D - DWELLING
STYLE:	L - LOG
FOUNDATION:	C - CONTINUOUS WALL
EXTERIOR WALL 1:	L - LOG
EXTERIOR WALL 2:	
ROOF STRUCTURE:	G - GABLE
ROOF COVER:	M - METAL
BEDROOMS:	3
FULL BATHS:	3
HALF BATHS:	
ADDITIONAL FIXTURES:	
FIREPLACE TYPE/CNT/OPN/CH:	ST/1/1/1
ELEVATOR TYPE/COUNT/STOPS:	
PHYS OVERRIDE:	
ECONOMIC DEPRECIATION:	
FUNCTIONAL DEPRECIATION:	
SPECIAL CONDITION CODE:	
SPECIAL CONDITION VALUE:	
DESCRIPTION:	1.5/S LOG DWLG
REMARKS:	
HEATED SQUARE FEET:	2,382

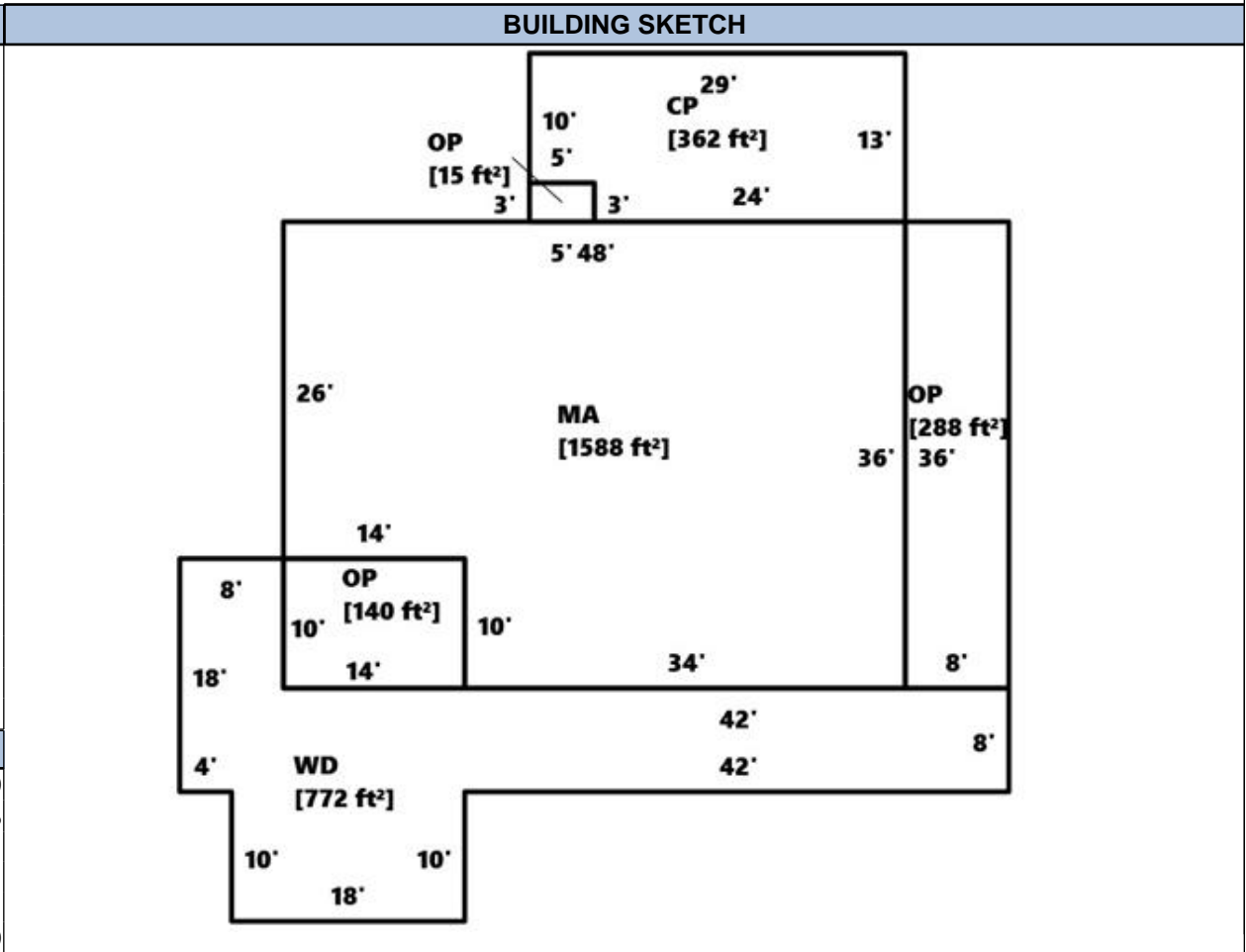

BUILDING COMPUTATION	
REPLACEMENT COST NEW	506,370
PHYSICAL DEPRECIATION	12%
FUNCTIONAL DEPRECIATION	
ECONOMIC DEPRECIATION	
% COMPLETE	
REPLACEMENT COST NEW LESS DEPRECIATION	445,600

BUILDING SECTION DETAIL														
TYPE	AREA	#ST	HEAT TYPE	HEAT%	AIR%	SPRINKLER%	GRADE	AYB	EYB	COND	P%	E%	F%	VALUE
MA	1588	1.5	P		100%		C+10	2008	2008	A	88%			287000
CP	362	1.0									88%			15800
FUS	794	1.0									88%			106500
OP	288	1.0									88%			12600
OP	140	1.0									88%			6100
OP	15	1.0									88%			700
WD	772	1.0									88%			16900